



**PEAR TREE
COMMUNITY
JUNIOR SCHOOL**

With trust & care we will grow & flourish

My Blended Learning Pack



Rainbow









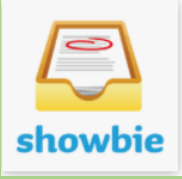

PEAR TREE
COMMUNITY
JUNIOR SCHOOL

With trust & care we will grow & flourish

My Passwords



	Username	Password
Showbie 		
Bug Club 		
Times Table Rockstars 		
Spelling Shed 		
Purple Mash 		
Flash Academy 		



Day One



English



Read

your



school



reading



book.

Phonics



Handwriting

S A T P I N

Maths



Superhero



counting

P.E



How



quickly

can you



get dressed?

General



Name

5



items

you find in the



kitchen.



Login



Bug Club





Day One



s s s s s s

a a a a a a

t t t t t t

p p p p p p

i i i i i i

n n n n n n



PEAR TREE
COMMUNITY
JUNIOR SCHOOL

With trust & care we will grow & flourish

Day One



Five red superheroes in a row. To the right is a large empty circle.

Three blue superheroes in a row. To the right is a large empty circle.

Eight blue superheroes in a row. To the right is a large empty circle.

Seven black superheroes in a row. To the right is a large empty circle.

Six red superheroes on yellow scooters in a row. To the right is a large empty circle.

Four blue superheroes in a row. To the right is a large empty circle.

Ten red superheroes in a row. To the right is a large empty circle.

Two blue superheroes in a row. To the right is a large empty circle.

Eight black superheroes in a row. To the right is a large empty circle.



Reflection



How are you feeling?



What



has



made



you



happy



today?

GRATITUDE JAR



What



would



you



change



about



today?

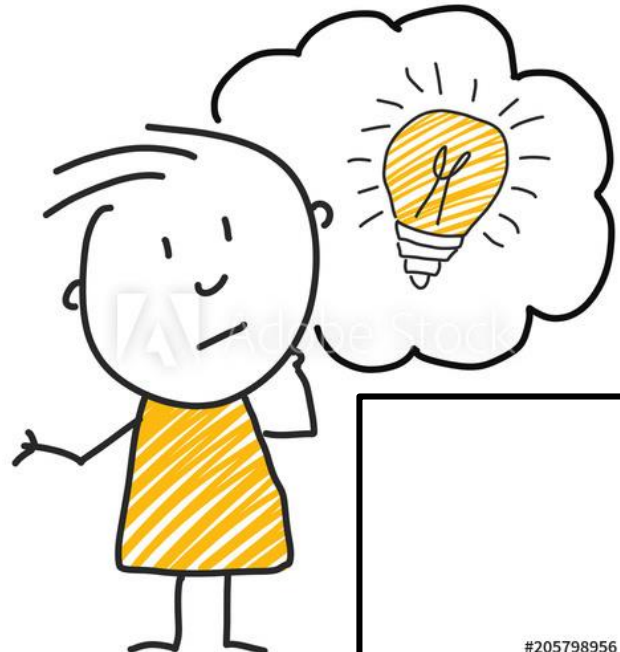

English



Complete the **HFW** worksheet.



Phonics



Match the first sound to the object.



Maths



Can you draw the correct amount?



P.E



How quickly can you get undressed?



General



Name 5 items you find in the bathroom.



Login



Bug Club





Day Two



Look and say	Look, say and write	Cover and write	Check and write again
in			
was			
is			
he			
it			

Fill in the missing word.

1. He was _____ the house.
2. Is _____ in the car? (the bag)
3. She _____ not in school. (now)
4. _____ is by himself.
5. It _____ Monday yesterday.

Write your own sentences using:

1. in
2. he
3. is



Day Two



Maths Amount	Show me
2	<input checked="" type="checkbox"/> <input checked="" type="checkbox"/>
6	
3	
9	
4	
11	
18	
5	
13	
10	



Day Two



s

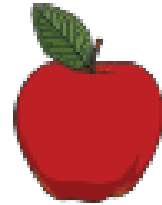

a



t



p



i



n

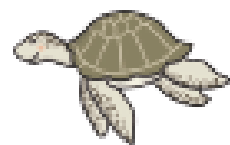
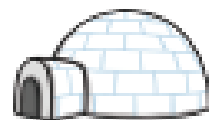



Reflection



How are you feeling?



What



has



made



you



happy



today?

GRATITUDE JAR



What



would



you



change



about



today?

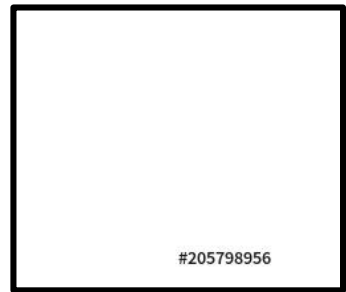
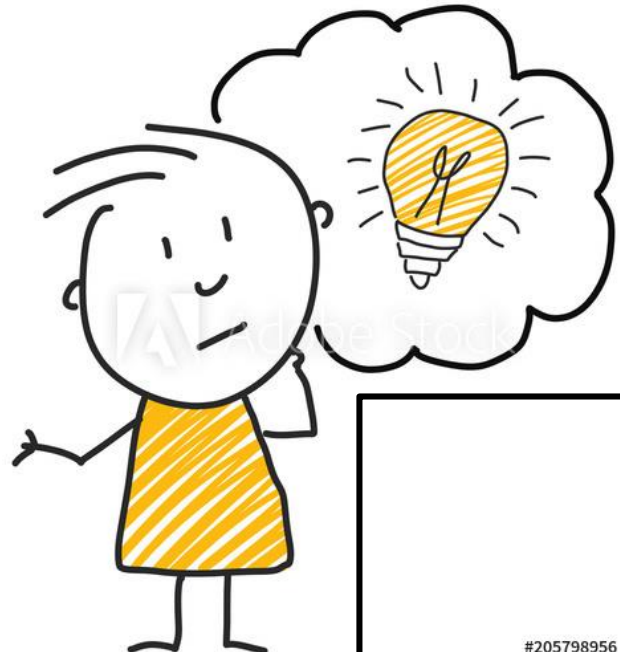



Day Three



English



Read

your



school



reading



book.

Phonics



Match

the



word

to



the picture

Maths



Write

your

numbers

in order



to

20

20

P.E



Practice



tying your shoe laces.

General



Find the

colours

in the

wordsearch.



Login



Bug Club





Day Three



sat



pin



tap



pan



nap



ant



tin

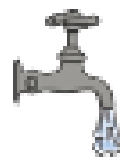

pat





Day Three



0
zero

1
one

4
four

5
five

2
two

3
three

6
six

7
seven

8
eight

9
nine

12
twelve

13
thirteen

10
ten

11
eleven

14
fourteen

15
fifteen

16
sixteen

17
seventeen

20
twenty

18
eighteen

19
nineteen



Day Three



Bow Prompt Pictures

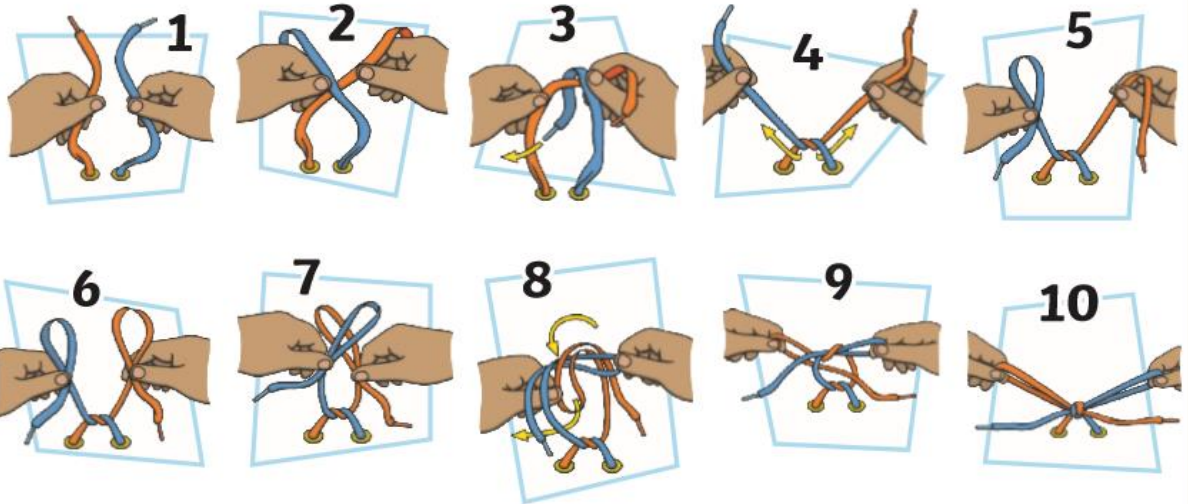

Bunny Ears Method



Bow Prompt Pictures

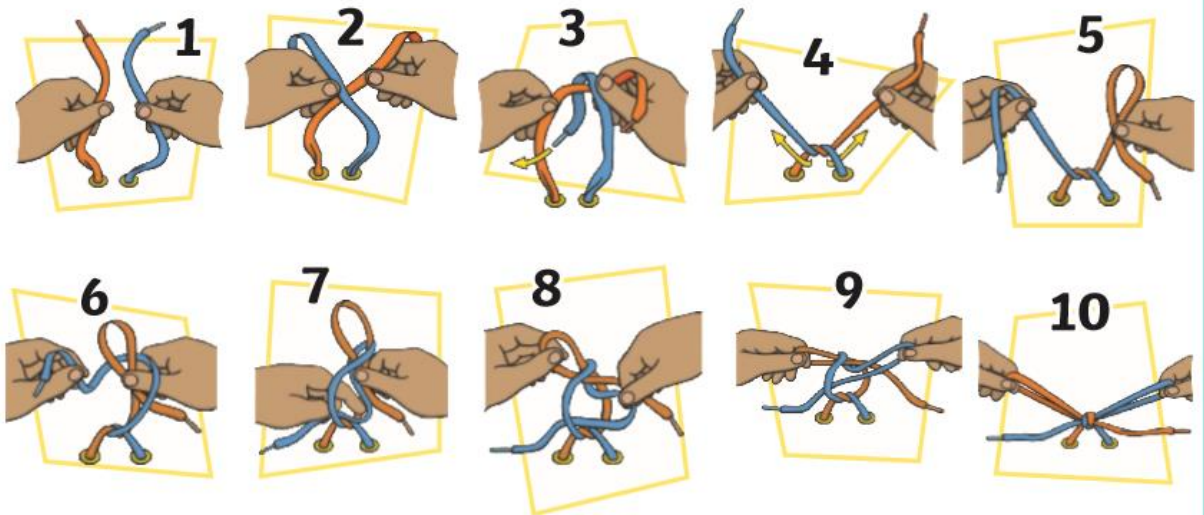

Traditional Method





Day Three



COLOURS



red



blue

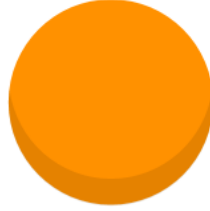

orange

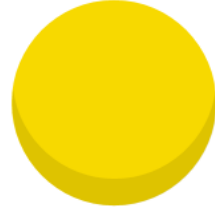

yellow



purple



black



green



pink



F	Y	L	J	D	L	G	R	E	E	N	W
R	L	S	K	B	D	J	R	F	I	Y	A
H	E	T	I	L	E	L	F	D	Y	T	M
I	R	D	P	U	Q	W	S	K	E	E	U
B	D	C	X	E	D	G	A	U	L	H	D
L	T	S	E	X	I	E	Q	R	L	U	I
A	I	O	R	A	N	G	E	P	O	N	P
C	Q	E	F	G	O	S	M	S	W	I	Y
K	A	K	Q	J	T	L	O	R	O	U	Q
P	U	R	P	L	E	I	L	Y	P	M	J
J	G	L	V	P	S	R	H	P	I	N	K
R	J	R	X	L	N	B	C	M	J	B	L





Reflection



How are you feeling?



What



has



made



you



happy



today?

GRATITUDE JAR



What



would



you



change



about



today?

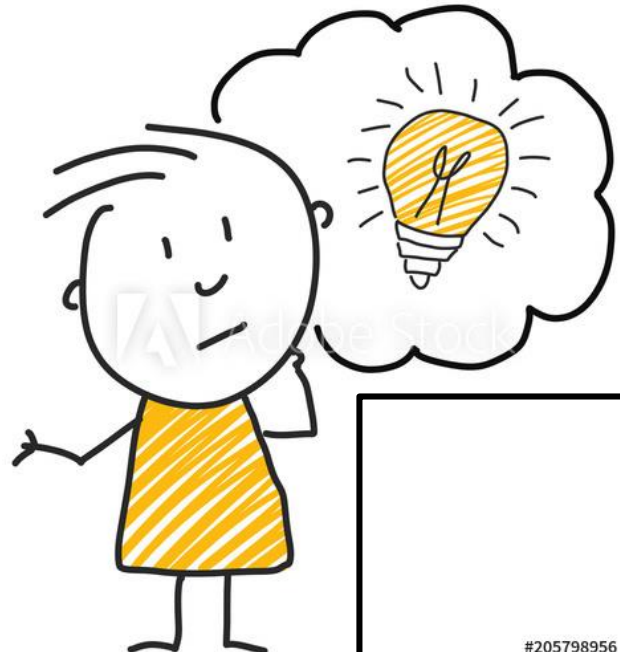



Day Four



English



Complete the **HFV** worksheet.



Phonics



Handwriting J V W X Y Z

Maths



Complete the number bonds to 10



P.E



Help



tidy a room



at home.

General



Complete the



Days

of the



Week



activity.



Login



Bug Club





Day Four



Look and say	Look, say and write	Cover and write	Check and write again
a			
the			
that			
to			
and			

Fill in the missing word.

- _____ cat was in the basket.
- Are you going over _____ their house?
- Jack _____ Jill went up the hill.
- Sorry, I did not hear _____.
- I would like _____ banana.

Write your own sentences using:

- a
- the
- and



Day Four



$0+10=10$

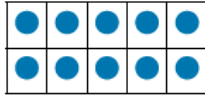

$4+6=10$

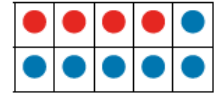

$1+9=10$

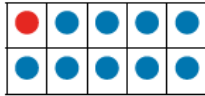

$5+5=10$

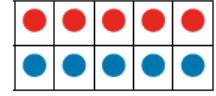

$2+8=10$

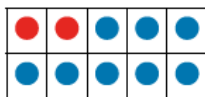

$6+4=10$

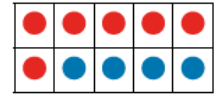

$3+7=10$

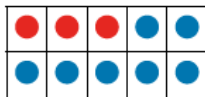

$7+3=10$

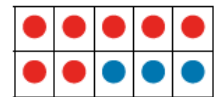

$8+2=10$

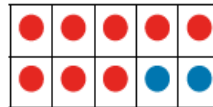

$9+1=10$

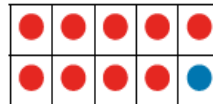

$10+0=10$

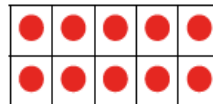







Day Four

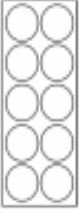





Number Bonds to 10

1)  + ? = 
 $10 + \square = 10$



2)  + ? = 
 $9 + \square = 10$



3)  + ? = 
 $8 + \square = 10$

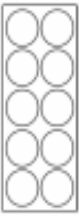

4)  + ? = 
 $7 + \square = 10$



5)  + ? = 
 $6 + \square = 10$



6)  + ? = 
 $5 + \square = 10$

7)  + ? = 
 $4 + \square = 10$

8)  + ? = 
 $3 + \square = 10$

9)  + ? = 
 $2 + \square = 10$

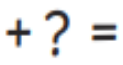
10)  + ? = 
 $1 + \square = 10$

11)  + ? = 
 $0 + \square = 10$





Day Four



Days of the Week

Monday

Tuesday

Wednesday

Thursday

Friday

Saturday

Sunday

twinkl www.twinkl.co.uk

Days of the Week Spellings

Write in the days of the week. Make sure you spell the word correctly.
The first letter has been given.

M _____

T _____

W _____

T _____

F _____

S _____

S _____

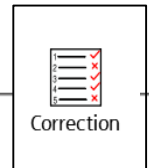
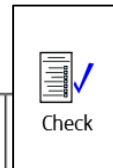
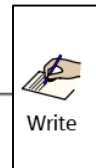
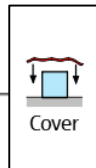
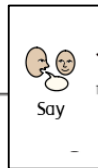
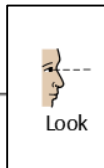

	Look	Say	Cover	Write	Check	Correction
Monday						
Tuesday						
Wednesday						
Thursday						
Friday						
Saturday						
Sunday						



Reflection



How are you feeling?



What



has



made



you



happy



today?

GRATITUDE JAR



What



would



you



change



about



today?

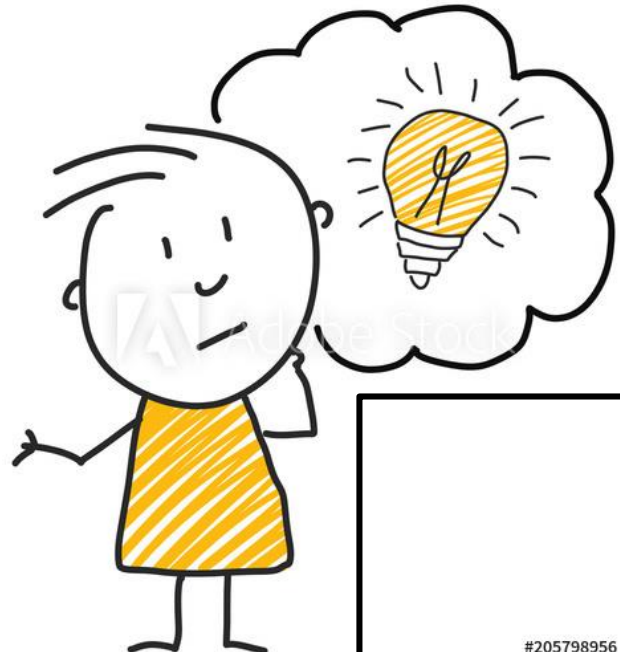



Day Five



English



Read

your



school



reading



book.

Phonics



Match

the first



sound

to the



object.

Maths



Calculate



one more

than the



amount

P.E



Help

an adult



to wash up.



General



Complete

the



months

of the



year



activity.



Login



Bug Club





Day Five



j



v



w



x



y



z









Day Five



one more





Day Five

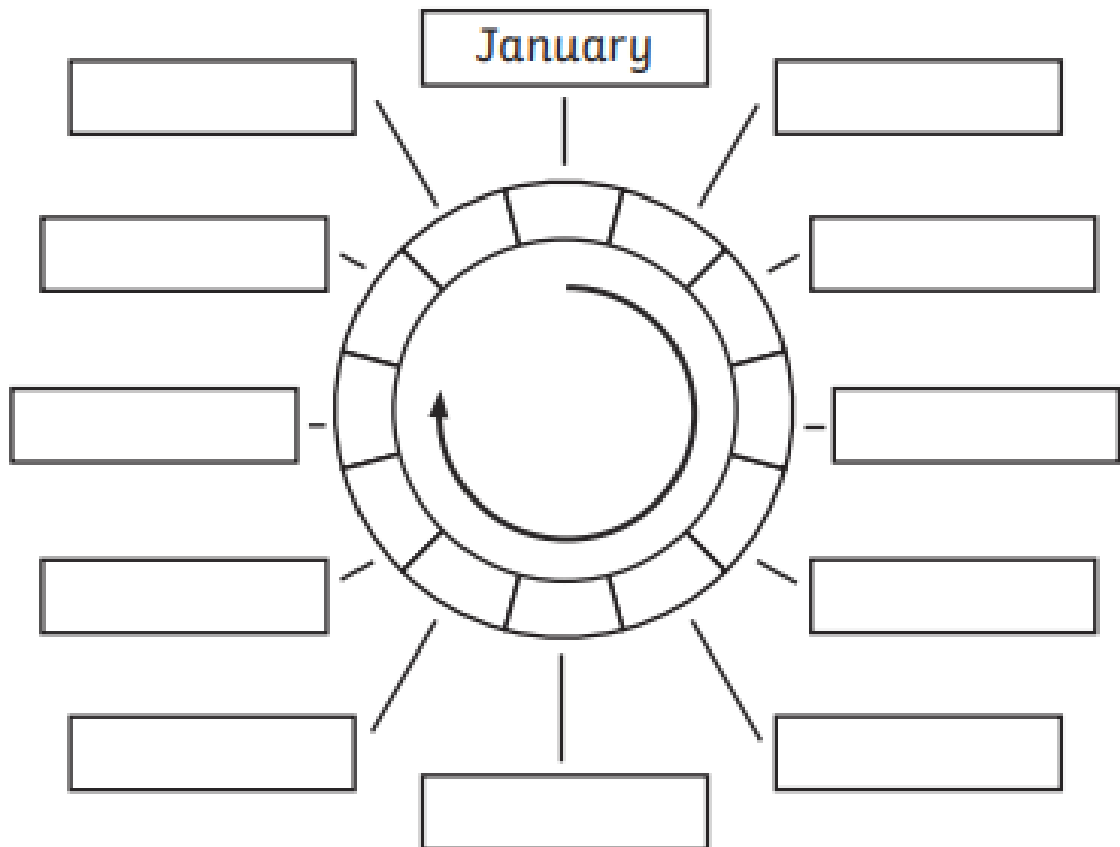



Reflection



How are you feeling?



What



has



made



you



happy



today?

GRATITUDE JAR



What



would



you



change



about



today?

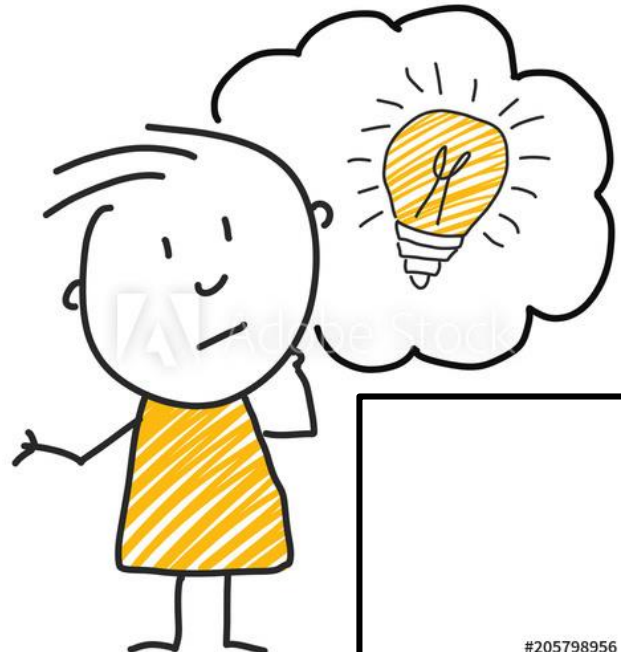



Day Six



English



Complete the **HFW** worksheet.



Phonics



Match the word to the picture



Maths



Calculate one less than the amount



P.E



Help an adult make a meal.



General



Draw and record the weather for the next 5 days.



Login



Bug Club





Day Six



Look and say	Look, say and write	Cover and write	Check and write again
of			
are			
for			
I			
you			

Fill in the missing word.

1. Are _____ here for me?
2. _____ will go there now.
3. She and I _____ very happy today.
4. I can see all _____ them.
5. Here is an apple _____ you.

Write your own sentences using:

1. I
2. for
3. you



Day Six



jam



van



jet



vet



jacket



Day Six



Write down what is one less in the circles

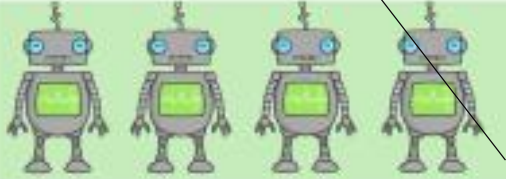

3



Click to add text





Day Six



Weather



fog



cold



clouds



showers



wet



snow



stormy



dry



hot



sleet



thunder



lightning



shine



hail

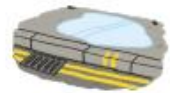

ice



rainbow



windy



sunny



rain



drizzle



Task: Keep a record of the weather during your week. Draw the weather symbol into the box for each day.



	Morning (before lunchtime)	Afternoon (after lunchtime)	Evening (hometime)
Monday			
Tuesday			
Wednesday			
Thursday			
Friday			

Count: How many days were...

- rainy? _____
- sunny? _____
- cloudy? _____
- windy? _____
- snowy? _____
- icy? _____
- stormy? _____



Reflection



How are you feeling?



What



has



made



you



happy



today?

GRATITUDE JAR



What



would



you



change



about



today?

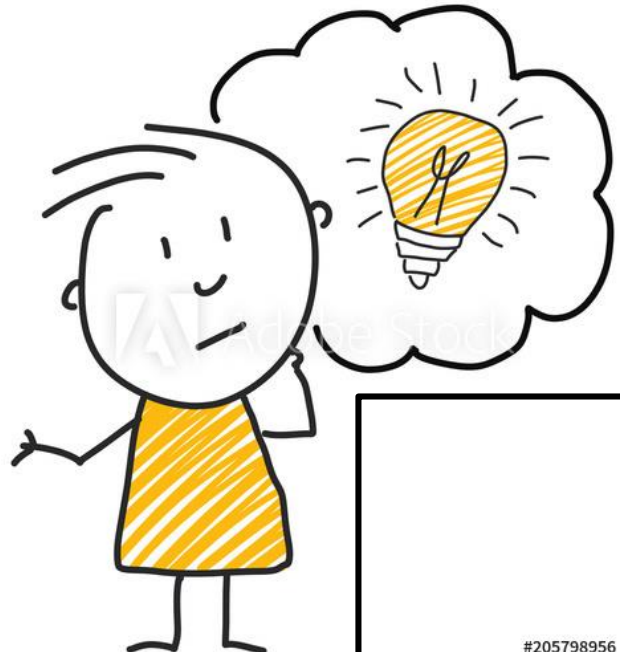



Day Seven



English



Read

your



school



reading



book.

Phonics



Handwriting

qu ch sh th ng ai

Maths



$3+1+2=$

Complete the addition calculations

P.E



How long

can you



balance

1



on one leg?

General



Match

the



picture

to the



season.



Login



Bug Club





Day Seven



qu qu qu qu qu qu

ch ch ch ch ch ch

sh sh sh sh sh sh

th th th th th th

ng ng ng ng ng ng

ai ai ai ai ai ai



Day Seven



10 pencils + 5 pencils =

A number line from 0 to 20 is shown below the pencils. The 10 pencils are placed from 0 to 10, and the 5 pencils are placed from 10 to 15.

10 chairs + 3 chairs =

A number line from 0 to 20 is shown below the chairs. The 10 chairs are placed from 0 to 10, and the 3 chairs are placed from 10 to 13.

15 red boxes + 2 red boxes =

A number line from 0 to 20 is shown below the boxes. The 15 boxes are placed from 0 to 15, and the 2 boxes are placed from 15 to 17.

10 pens + 6 pens =

A number line from 0 to 20 is shown below the pens. The 10 pens are placed from 0 to 10, and the 6 pens are placed from 10 to 16.

10 blue blocks + 6 blue blocks =

A number line from 0 to 20 is shown below the blocks. The 10 blocks are placed from 0 to 10, and the 6 blocks are placed from 10 to 16.



Day Seven



12

+

8

=



13

+

2

=



7

+

9

=



11

+

6

=



9

+

9

=





Day Seven

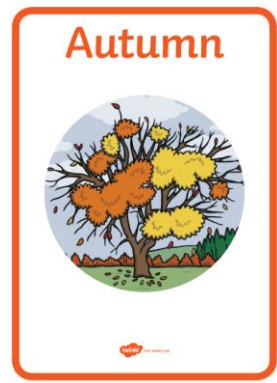
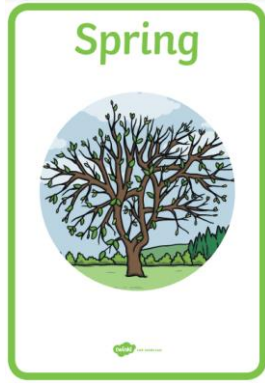

Days, Months and Seasons Word Mat

Seasons			
 Spring blossom tadpoles frogspawn hatch breeze chick buds flowers butterfly grow lamb	 Summer green leaves sun lawnmower daisy thunder holiday sunflower birds worm swimming sand castle	 Autumn trees rain corn scarecrow foliage rake bread leaves windy tractor pumpkin harvest	 Winter snowman ice snowflakes cold woolly hat Christmas icicles gloves skis ice skating scarf jumper
Months		Days	
January February March April May June 	July August September October November December	Monday Tuesday Wednesday Thursday Friday	Saturday Sunday



Match



the picture



to the season.

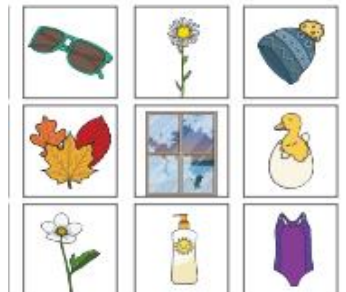
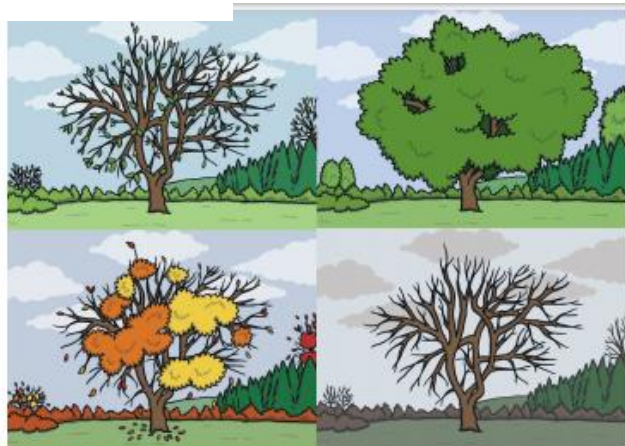



Reflection



How are you feeling?



What



has



made



you



happy



today?

GRATITUDE JAR



What



would



you



change



about



today?

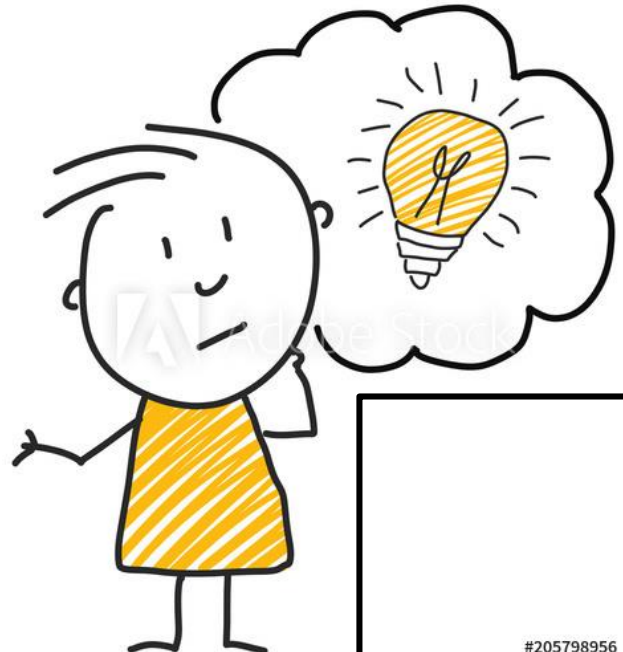



Day Eight



English



Complete the **HFW** worksheet.



Phonics



Match the sound to the picture



Maths



3-1-2=

Complete the subtraction calculations

P.E



Throw and catch a ball with someone.



General



Practice some important phrases to



help you at school.



Login



Bug Club



Look and say	Look, say and write	Cover and write	Check and write again
had			
so			
have			
said			
as			

Fill in the missing word.

1. _____ he said yes?
2. _____ we had this before?
3. She _____ been sick.
4. The girl _____ that to him.
5. I am as happy _____ I can be.

Write your own sentences using:

1. have
2. said
3. had



Day Eight









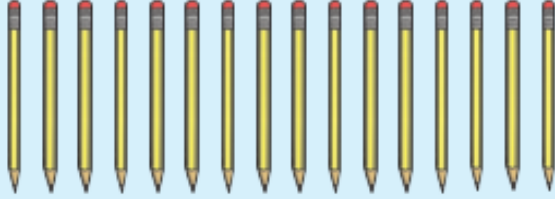

ai
ng
qu
sh
th
ch



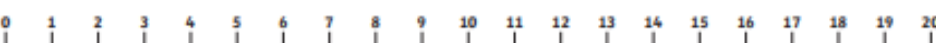
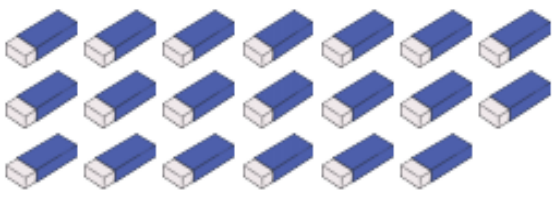

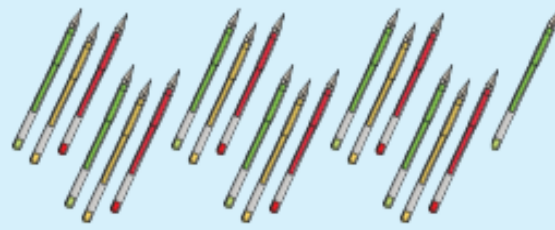
Day Eight

 $- 5 = \bigcirc$  $- 8 = \bigcirc$  $- 2 = \bigcirc$  $- 8 = \bigcirc$  $- 4 = \bigcirc$ 



Day Eight



$$20 - 6 = \bigcirc$$

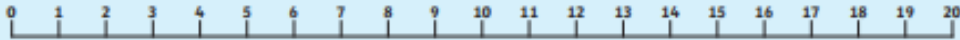

$$17 - 9 = \bigcirc$$



$$14 - 6 = \bigcirc$$



$$16 - 5 = \bigcirc$$



$$19 - 6 = \bigcirc$$





Day Eight



Practice saying these phrases for school.

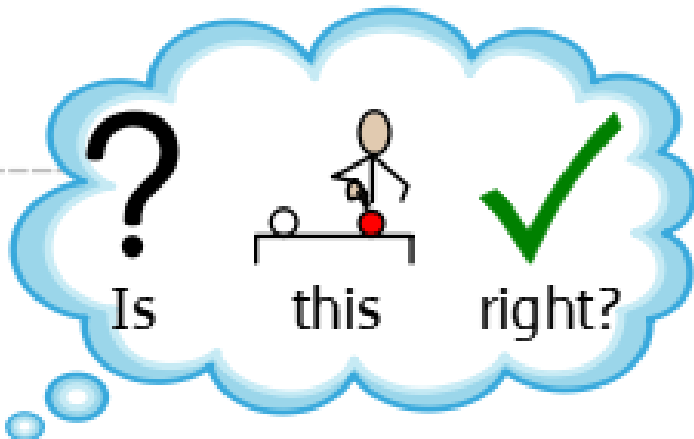
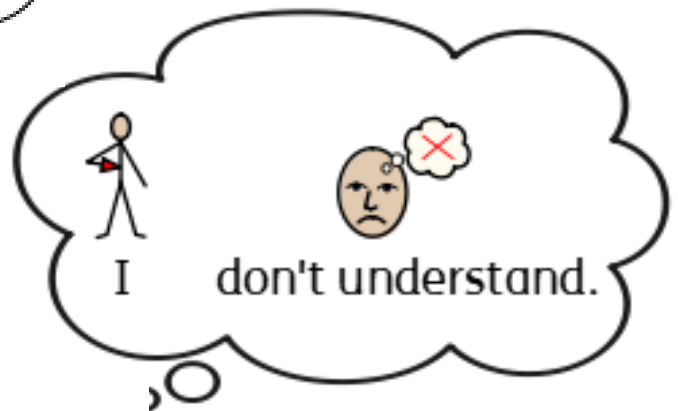
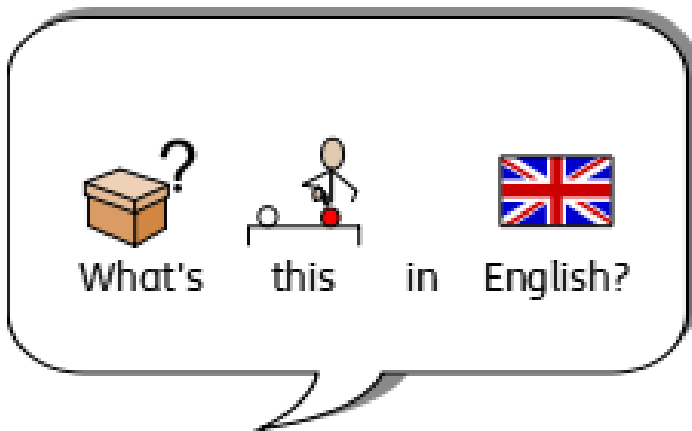



Reflection



How are you feeling?



What



has



made



you



happy



today?

GRATITUDE JAR



What



would



you



change



about



today?

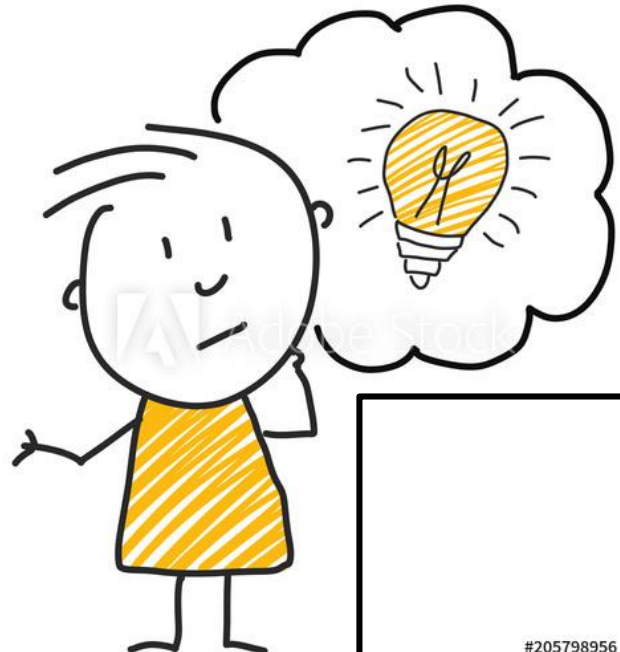

English



Read

your



school



reading



book.

Phonics



Match

the



word

to



the picture

Maths



Find

all the different 2D



shapes

P.E



Complete

5



hops

on your



right



leg.



Complete

5



stamps

with your



right



foot.

General



Practice



some



important



phrases to



help



you



at school.



Login



Bug Club





Day Nine

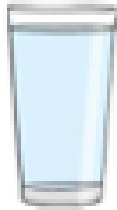

liquid



chicken

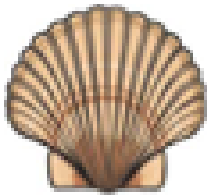

shed



fish

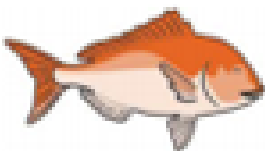

shell



Day Nine



2D Shape Word Mat

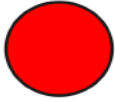

circle



rectangle



triangle

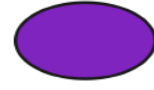

oval



octagon



square

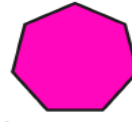

heptagon



rhombus



pentagon



hexagon



kite

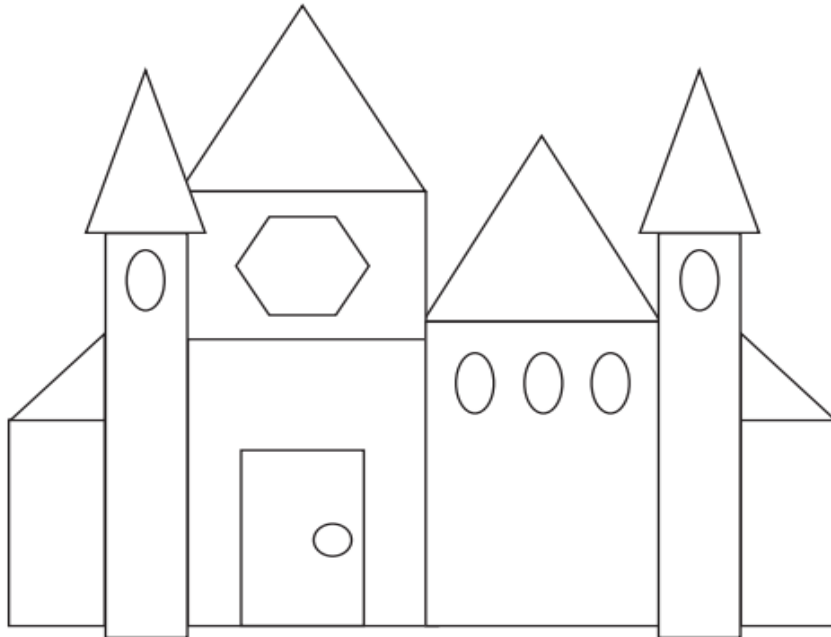

I can see ____ circle.

I can see ____ triangles.

I can see ____ rectangles.

I can see ____ hexagon.

I can see ____ ovals.



Day Nine



Practice saying these phrases for school.



How do you pronounce that in



English?



How do you spell it?



Can you say that again, please?

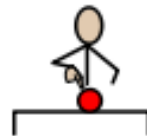

What's the time?

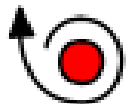

Sorry I'm late.



Reflection



How are you feeling?



What



has



made



you



happy



today?

GRATITUDE JAR



What



would



you



change



about



today?

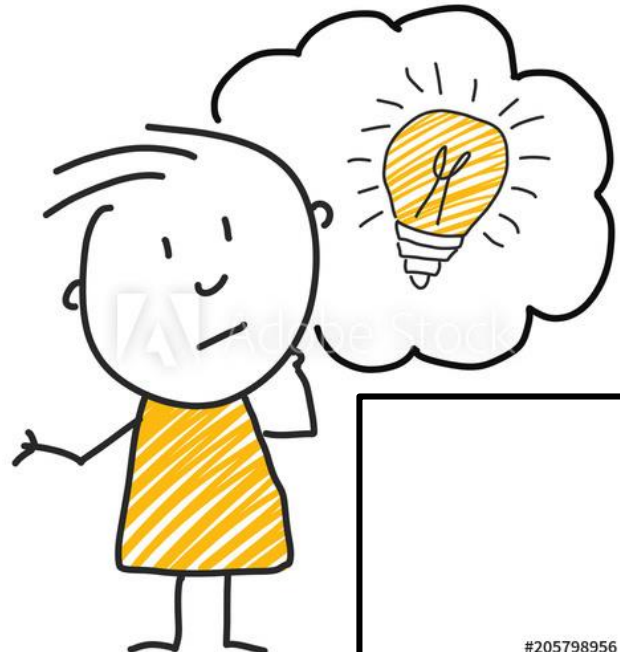



Day Ten



English



Complete the **HFV** worksheet.



Phonics



Swap the words in the sentence...



Maths



Find all the different 3D shapes



P.E



Complete 5 hops on your left leg.

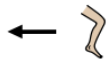

Complete 5 stamps with your left foot.



General



Practice some important phrases to



help



you



at school.



Login



Bug Club





Day Ten



Look and say	Look, say and write	Cover and write	Check and write again
not			
they			
with			
one			
we			

Fill in the missing word.

1. They are not _____ us.
2. _____ of them will stay here.
3. I am _____ very happy.
4. _____ are not being as good as us.
5. _____ will be there soon.

Write your own sentences using:

1. with
2. they
3. one



Day Ten



Swap

U

the underlined



word

with the one from the



box



below.

Carl sat down on the carpet.

The sheep are in the shed.

I can see a toad on the road.

She has had lots of books.

They might meet in the town.

pool

goats

moon

boots

farmyard

chair

fish

car



Day Ten



3D Shapes



square-based pyramid



triangular prism



cone

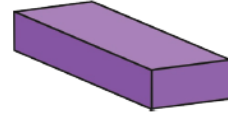

cuboid

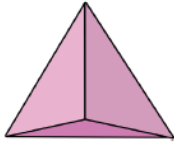

tetrahedron



cube



cylinder

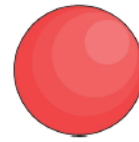

sphere

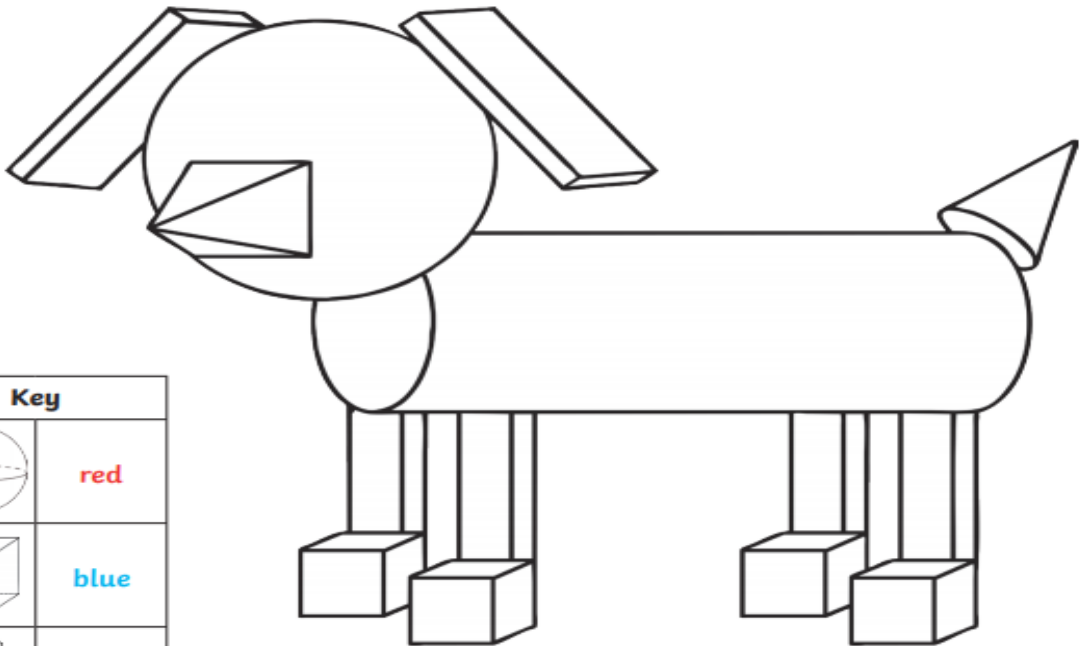

Key	
	red
	blue
	green
	purple
	orange
	yellow



Day Ten



Practice saying these phrases for school.

?



Could you speak slowly, please?

?



Could you speak loudly, please?

?



Can I have some water,



please?

?



Can I come in?

?



?

Could you repeat the question?



Reflection



How are you feeling?



What



has



made



you



happy



today?

GRATITUDE JAR



What



would



you



change



about



today?

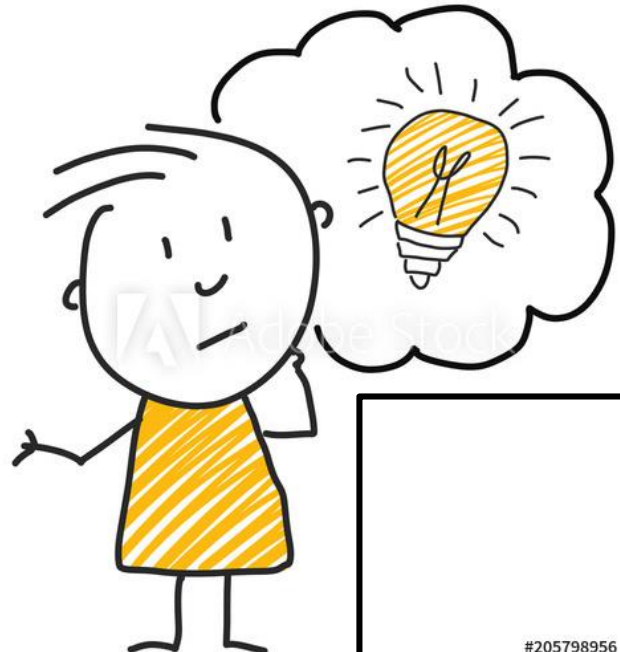



PEAR TREE
COMMUNITY
JUNIOR SCHOOL



























With trust & care we will grow & flourish

























Visual prompts



My Alphabet Mat

a 	b 	c 	d 	e 	f 	g 	h 	i 
j 	k 	l 	m 	n 	o 	p 	q 	r 
s 	t 	u 	v 	w 	x 	y 	z 	

My Phase 2 Sound Mat

s 	a 	t 	p 	i 	n 	m 	d 
g 	o 	c 	k 	ck 	e 	u 	r 
h 	b 	f 	ff 	l 	ll 	ss 	



My Phase 3 Sound Mat



















j 	v 	w 	x 	y 	z 	zz 	qu 		
ch 	sh 	th 	ng 	ai 	ee 	igh 	oa 		
oo 	oo 	ar 	or 	ur 	ow 	oi 	ear 		
air 	ure  Pure	er 	 visit twinkl.com						

My Phase 4 Sound Mat

st  starfish	nd  hand	mp  lamp	nt  tent	nk  ink	ft  gift	sk  tusk	lt  belt
lp  help	lf  shelf	lk  milk	pt  script	xt  text	tr  tree	dr  drawing	gr  grandpa
cr  crab	br  brush	fr  frog	bl  blackberry	fl  flag	gl  glasses	pl  plane	cl  clown



My Phase 5 Sound Mat

ay 	ou 	ie 	ea 	oy 	ir 	ue 	ue 
aw 	wh 	ph 	ew 	ew 	oe 	au 	ey 
a-e 	e-e* 	i-e 	o-e 	u-e 	u-e 		

*even

100 High Frequency Words

the	his	be	do	into	house
and	but	like	me	back	old
a	that	some	down	from	too
to	with	so	dad	children	by
said	all	not	big	him	day
in	we	then	when	Mr	made
he	can	were	it's	get	time
I	are	go	see	just	I'm
of	up	little	looked	now	if
it	had	as	very	came	help
was	my	no	look	oh	Mrs
you	her	mum	don't	about	called
they	what	one	come	got	here
on	there	them	will	their	off
she	out			people	asked
is	this			your	saw
for	have			put	make
at	went			could	an



My Feelings



visit twinkl.com

My Body

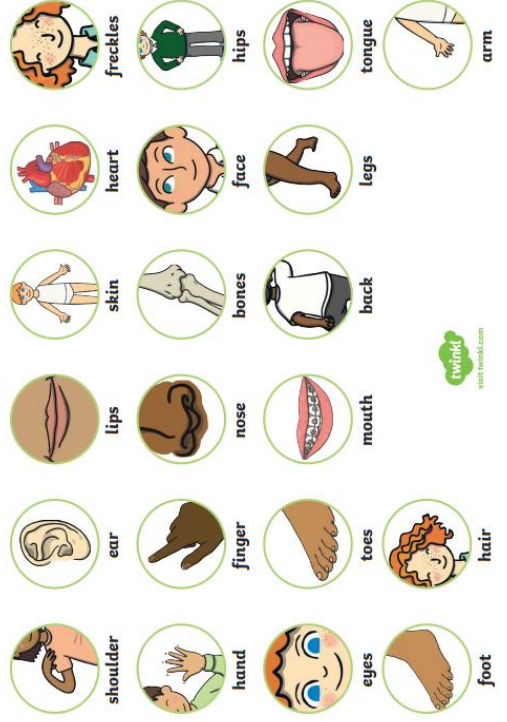

visit twinkl.com

My Family

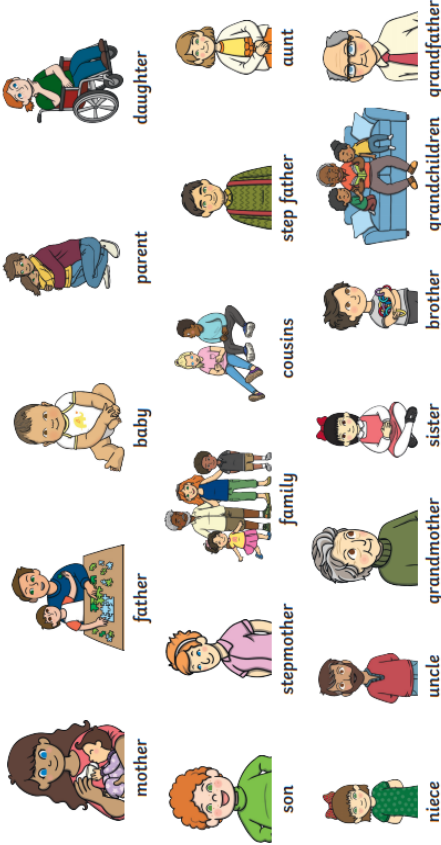

visit twinkl.com

Instructions

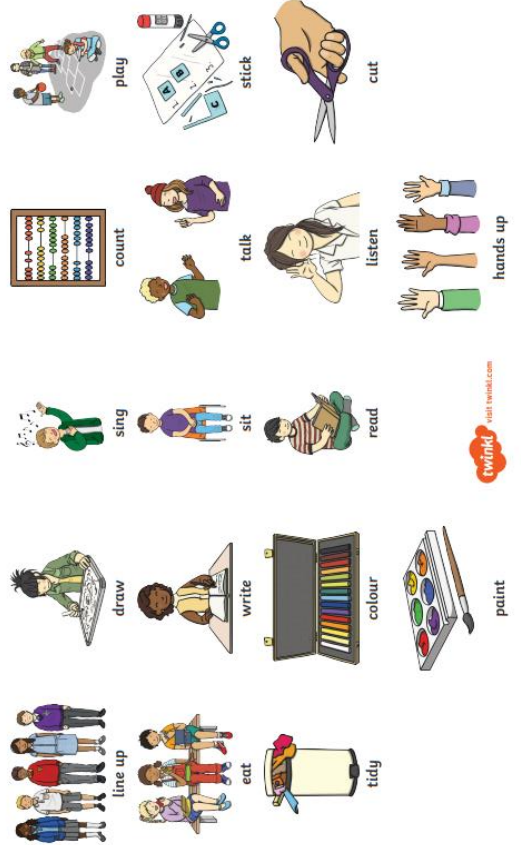

visit twinkl.com



PEAR TREE
COMMUNITY
JUNIOR SCHOOL

With trust & care we will grow & flourish



Extra support



**PEAR TREE
COMMUNITY
JUNIOR SCHOOL**

With trust & care we will grow & flourish



Now



Next



Reward



Phonics



Break Time



Lunch Time



English

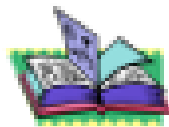

Maths



Computing



P.E



Cross-Curricular Learning





My Targets

Target	How can you help me at home?





When upset, try the following:

I can calm myself down

1

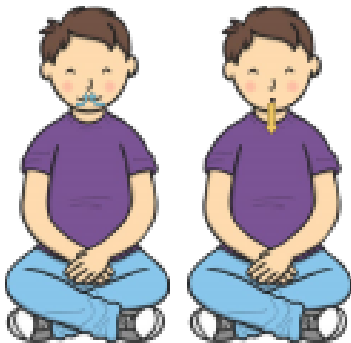

Take deep breaths.

I can calm myself down

2



Keep hands and feet to myself.

I can calm myself down

3

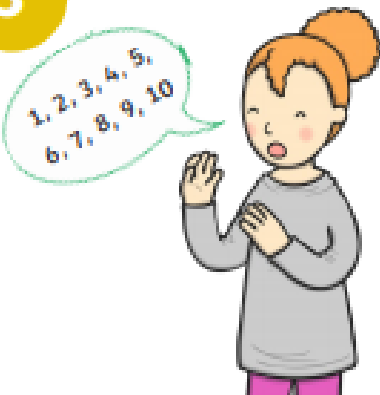

Count to ten.

I can calm myself down

4



Think about what I am trying to say.



Positive Phrases

Don't Say...	Say...	
Be quiet.	Can you use your quiet voice?	
Look at this mess!	What can we do to tidy this up?	
Do you need help?	I'm here if you need me.	
I have already explained this.	Can I show you another way?	
Stop crying.	I can see you are upset. Would you like to tell me about it?	

Fantastic!

Super!

Great job!

Well done!

Great effort!

Brilliant!

Great focus!

Super enthusiasm!

Don't Say...	Say...	
Do you have any questions?	Do you think you can get started?	
You're OK.	Tell me how you're feeling.	
It's not hard.	You can do this!	
Don't shout.	I can see you are angry. What can I do to help?	
Stop it.	Could you use a rest/break?	



PEAR TREE
COMMUNITY
JUNIOR SCHOOL

With trust & care we will grow & flourish



Mindfulness



PEAR TREE
COMMUNITY
JUNIOR SCHOOL

With trust & care we will grow & flourish

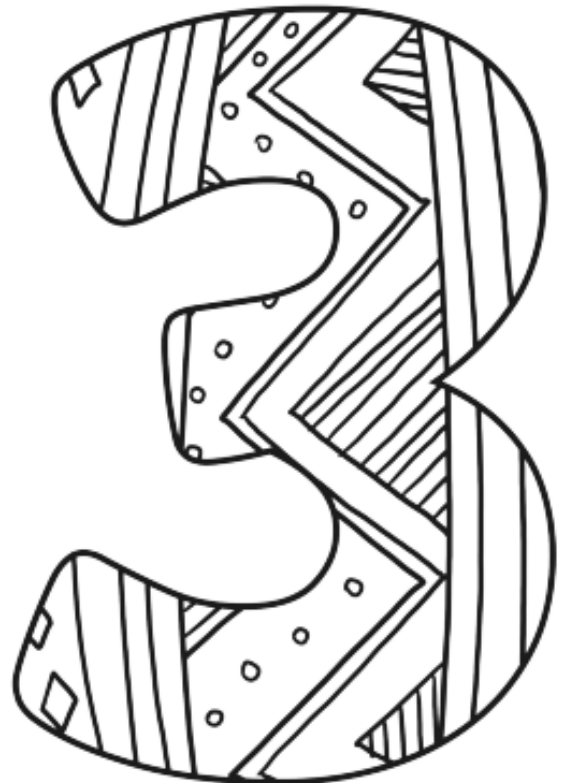
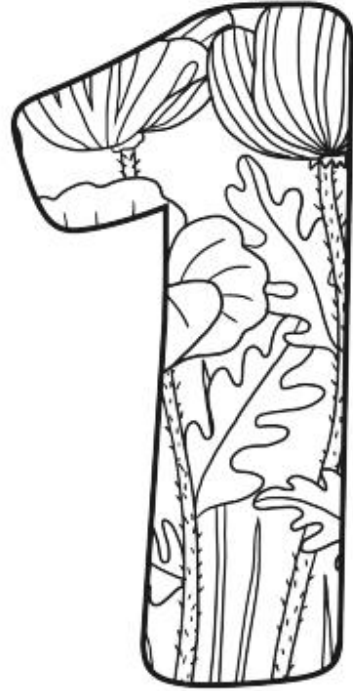



PEAR TREE
COMMUNITY
JUNIOR SCHOOL

With trust & care we will grow & flourish





PEAR TREE
COMMUNITY
JUNIOR SCHOOL

With trust & care we will grow & flourish



We're All In This



Together